

## The Biology of Manual Therapies

Brian C. Clark, PhD; James S. Thomas, PT, PhD; Stevan A. Walkowski, DO; and John N. Howell, PhD

Each year, more than 18 million adults in the United States receive manual therapies, at a total annual out-of-pocket cost of \$3.9 billion. Although there is growing evidence supporting the efficacy of manual therapies, little is known about the mechanisms underlying these treatments. This lack of basic knowledge significantly limits the development of rational strategies for the use of these treatments and potentially hinders their acceptance by the wider scientific and health care communities. Many authors have hypothesized that manual therapies act by disrupting the pain-spasm-pain cycle, but relatively little experimental evidence has supported this hypothesis. The authors have tested this hypothesis and summarize their work on the biology of manual therapies.

*J Am Osteopath Assoc.* 2012;112(9):617-629

Many scientists and clinicians have postulated that manual therapies exert biologic effects on the nervous system.<sup>1-16</sup> It has been hypothesized that manual therapies act mechanistically to disrupt the pain-spasm-pain cycle.<sup>9,17</sup> In brief, the conceptual basis for this cycle is that pain leads to muscular hyperactivity (spasm), which in turn causes or exacerbates pain (see *Pain-Spasm-Pain Cycle*).<sup>18</sup> Although 2 distinct neural pathways have been proposed to support this model,<sup>19</sup> each pathway operates on the basis of the same concept, namely, that increased excitatory input to the  $\alpha$ -motoneuron pool leads to more sustained and intense muscle activity. More than 3 decades ago, Korr<sup>7</sup> hypothesized that manual therapies act to disrupt the pain-spasm-pain cycle by reducing the excitability of the monosynaptic stretch reflex (also known as myotatic reflex, deep tendon reflex, or muscle spindle reflex). However, relatively few studies have quantified the effects of manual therapies on muscle activity<sup>20-24</sup> or stretch reflex excitability in humans,<sup>4,25-28</sup> and thus, there are still limited empirical data describing the effects and consequences of manual therapies.

Our work has focused on the mechanistic effects of manual therapies. The studies profiled here tested the hypothesis that manual therapies act to disrupt the pain-spasm-pain cycle. In this article, we review our latest work on the biology of manual therapies. We will briefly review the anatomy and physiology of muscle spindles, then discuss the pain-spasm-pain cycle, and finally present the findings from these studies, providing our perspectives on key questions to be addressed in future research.

### Muscle Spindles

The scientific knowledge and understanding of human muscle and nerve physiology has grown exponentially during the past several decades with the advent of non-invasive methodologies to study *in vivo* characteristics. For example, at the start of the 20th century, the classic works by Hoffmann<sup>29</sup> describing the Hoffmann reflex (H-reflex) and by Liddell and Sherrington<sup>30</sup> describing the stretch reflex led to a plethora of studies that expanded our understanding of spinal and muscle reflex properties. Today, the term “sensorimotor control” highlights the inseparable coupling that exists between proprioceptive sensory feedback and motor command. Sensory input

---

From the Ohio Musculoskeletal and Neurological Institute (Drs Clark, Thomas, Walkowski, and Howell), the Department of Biomedical Sciences (Drs Clark, Thomas, and Howell), the Department of Family Medicine (Dr Walkowski), and the School of Rehabilitation and Communication Sciences (Dr Thomas) at Ohio University in Athens.

Dr Clark delivered a presentation highlighting these findings at The Osteopathic Research Center's 10th annual conference, Using Manual and Conventional Therapies to Enhance Musculoskeletal Health, which was held April 27 through April 29, 2012, in Fort Worth, Texas.

**Financial Disclosures:** None of the authors have any potential conflicts to disclose related to the opinions of data in the current study. The work presented in this article was supported by grants from the Osteopathic Heritage Foundations and the American Osteopathic Association.

Address correspondence to Brian Clark, PhD, Ohio University, OMNI and Department of Biomedical Sciences, 236 Irvine Hall, Athens, OH 45701.

E-mail: clarkb2@ohio.edu

Submitted July 15, 2012; revision received August 6, 2012; accepted August 8, 2012.

## BRIEF REPORT

arises from a variety of sources, and one key input to spinal and cortical processing of sensory information arises from the muscle spindles, which is easily demonstrable by the illusions of movement that are created when the activity of these sensors are manipulated.<sup>31-33</sup> *Figure 1* illustrates the key anatomic features and neuropathways of muscle spindles. Additionally, we refer the reader to the Web site maintained by Arthur Prochazka, PhD, of the University of Alberta for an interactive model explaining muscle spindle behavior: <http://www.angeltar.com/spindle/spindle.html>.

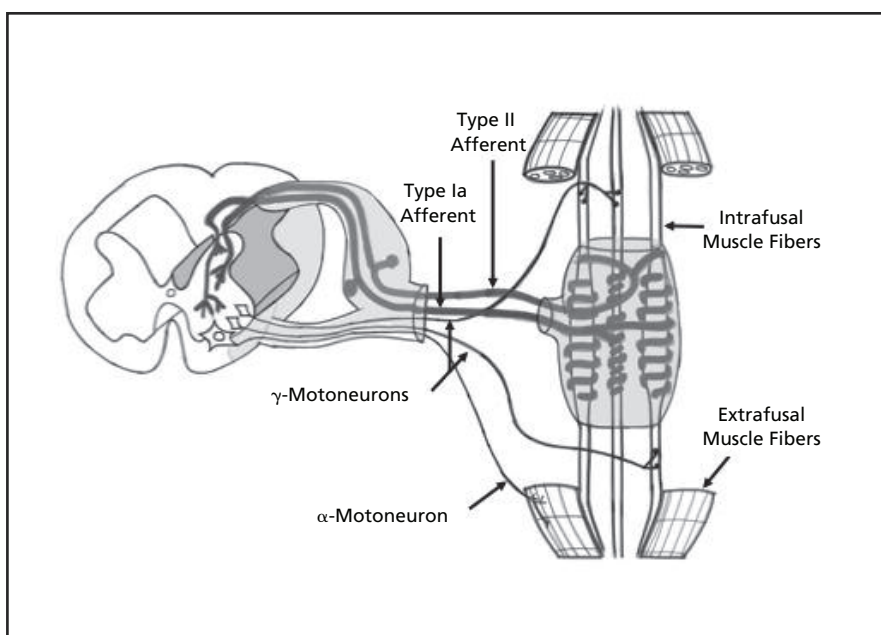
Muscle spindles relay sensory information on the length of and changes in the length of a muscle.<sup>34,35</sup> Muscle spindles are collections of specialized muscle fibers (ie, intrafusal muscle fibers) that are not part of the high-force-producing muscle mass itself (ie, extrafusal muscle fibers that are innervated by  $\alpha$ -motoneurons).<sup>35</sup> Although intrafusal fibers do not contribute substantially to the force produced during muscle contraction, they do have contractile elements at their ends that are innervated by  $\gamma$ -motoneurons.<sup>35</sup> Muscle spindles reside parallel to extrafusal muscle fibers, stretching alongside these muscle fibers during both active and passive movements. Muscle spindles contain nuclear chain and dynamic and static nuclear bag fibers, which have different shapes and convey different types of information.<sup>35</sup> Group Ia afferents (primary afferents) have annulospiral endings that wrap around the central portion of all 3 types of intrafusal fibers and transmit information about both length and rate of length change.<sup>36</sup> Group II afferents (secondary afferents) have flower spray endings that innervate the ends of the nuclear chain fibers,

and the static nuclear bag fibers transmit only information about muscle length.<sup>36</sup> The excitability of the muscle spindles is regulated by the activity of  $\gamma$ -motoneurons.<sup>36</sup> When  $\gamma$ -motoneurons fire, they cause the intrafusal muscle fibers to contract, which makes the muscle spindle more taut and in turn increases the overall excitability of the spindle (ie, increases the afferent discharge rate).

### Pain-Spasm-Pain Cycle

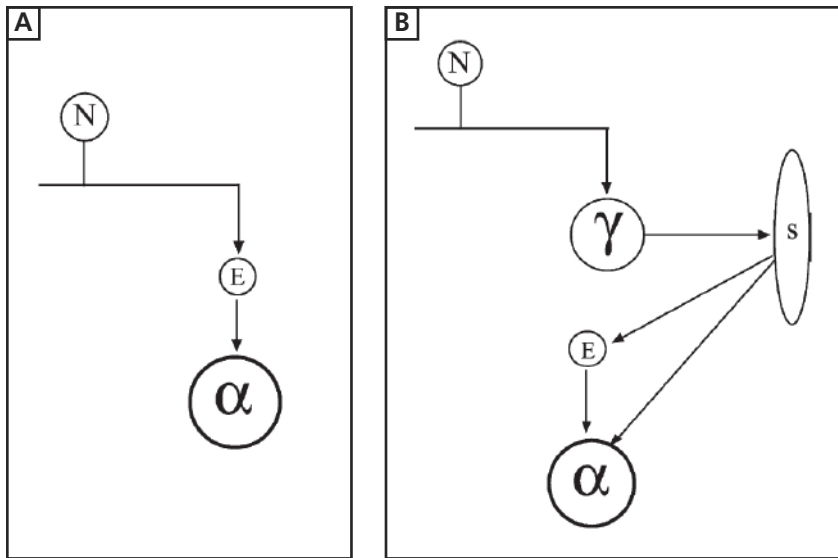
The pain-spasm-pain cycle is the concept whereby pain leads to muscular hyperactivity (spasm), which in turn causes or exacerbates pain.<sup>18</sup> The theoretical rationale for the pain-spasm-pain cycle is illustrated in *Figure 2*. Two potential neural pathways have been posited as the basis of the pain-spasm-pain cycle.<sup>19</sup> In one of the proposed pathways, nociceptive afferents directly transmit to excitatory interneurons and then to  $\alpha$ -motoneurons, resulting in increased muscle activation (spasm). In the other proposed pathway, the muscle spindles serve as a key anatomic structure involved in a feed-forward loop. The loop begins when nociceptive fibers provide excitatory input to the  $\gamma$ -motoneurons that increase the sensitivity of muscle spindles. This increased spindle sensitivity heightens spindle afferent activity and thus increases excitatory input to the  $\alpha$ -motoneurons, further increasing muscle activation and pain.

Numerous neurophysiologic studies have been conducted to verify the existence of the pain-spasm-pain cycle and the underlying neural pathways involved. A complete discussion of this evidence can be found in articles by van Dieën et al<sup>19</sup> and Knutson.<sup>6</sup> The majority of these studies



**Figure 1.** Anatomic and neural pathways of the muscle spindle.

examined whether nociceptive substances that increase the discharge rate of the chemosensitive group III and IV muscle afferents (eg, arachidonic acid, bradykinin, lactate) also increased the discharge rate of muscle spindle afferents. A series of elegant studies<sup>37-43</sup> conducted by scientists at the Centre for Musculoskeletal Research at Sweden's National Institute for Working Life provided strong evidence that a wide variety of nociceptive stimuli excite muscle spindle afferents in animals. For example, a series of articles from Djupsjöbacka et al<sup>37-39</sup> from the mid-1990s reported that injections of arachidonic acid, lactic acid, potassium chloride, and bradykinin increased the firing rate of primary and secondary muscle spindle afferents in cats.<sup>37-39</sup> A follow-up study<sup>41</sup>



**Figure 2.** Two theoretical neural pathways suggested as the basis of the pain-spasm-pain cycle. In panel A, nociceptive afferents (N) transmit feedback via excitatory interneurons (E) to the  $\alpha$ -motoneurons ( $\alpha$ ) that cause increased muscle activation (spasm). In panel B, nociceptive afferents (N) provide excitatory input on the  $\gamma$ -motoneurons ( $\gamma$ ) that increase the sensitivity of the muscle spindles (s), which activate  $\alpha$ -motoneurons via excitatory interneurons (E) further increasing muscle activation and pain. Reprinted from van Dieën et al<sup>19</sup> with permission from Elsevier.

from this group found that an injection of bradykinin in combination with muscle stretch induces potent and long-lasting excitatory effects on muscle spindle afferents, indicating that stretch-sensitive nerve endings are sensitized by nociceptive stimuli. Interestingly, these data suggest that the nociceptive inputs are acting on the  $\gamma$ -efferent neurons rather than acting directly on the muscle spindles, as the effects were observed in homo- and heteronymous muscles, including contralateral muscles.<sup>38,41</sup> Conversely, other studies of animals report no change in muscle spindle afferent activity in response to nociceptive stimuli.<sup>44-46</sup>

Data on the existence of the pain-spasm-pain cycle in humans are also conflicting. For instance, Matre et al<sup>8</sup> reported that a 5% hypertonic saline infusion to the soleus and tibialis anterior muscles (experimentally inducing muscle pain) increased stretch reflex in the painful muscles. Similar observations, at least in resting muscles, have also been reported by others.<sup>47,48</sup> However, Zedka et al<sup>49</sup> observed that a hypertonic saline infusion into the human lumbar erector spinae muscles did not modulate the stretch reflex in the back muscles, and Birznieks et al<sup>50</sup> observed that experimental muscle pain did not influence muscle spindle afferent activity recorded by means of microneurography. Thus, although there is clear evidence supporting existence

of the pain-spasm-pain cycle in certain models and muscle groups, that evidence is sometimes disputed.

### The Biology of Manual Therapies

The series of studies summarized in the following subsections tested whether manual therapies acted to disrupt the pain-spasm-pain cycle. The first of these studies examined the acute effects of strain-counterstrain treatment to modulate changes in the H- and stretch-reflexes of the plantar flexor muscles in patients with Achilles tendinitis.<sup>4</sup> The second study examined the effects of osteopathic manipulative treatment (OMT) to reduce resting muscle activity, as assessed by means of muscle func-

tional magnetic resonance imaging (mfMRI) in patients with acute low back pain (LBP).<sup>21</sup> For this study, the authors hypothesized that if manual therapies truly acted to disrupt the pain-spasm-pain cycle, then one should observe a reduction in resting muscle activity (ie, decreased resting muscle hyperactivity/spasm). The third study examined the effects of high-velocity, low-amplitude (HVLA) spinal manipulation on the amplitude of stretch reflexes and motor evoked potentials (assessed by means of transcranial magnetic stimulation) of the erector spinae muscles in patients with chronic LBP.<sup>25</sup> The most recent study,<sup>51</sup> in 2012, focused on the effects of nonthrust manual therapies (ie, treatment techniques that use a low-velocity, low-force approach) on the erector spinae short-latency stretch reflex.

### Study 1. Stretch reflex and Hoffman reflex responses to OMT in patients with Achilles tendinitis<sup>4</sup>

The purpose of this study was to determine if strain-counterstrain manual therapy reduced the sensitivity of the short-latency (ie, monosynaptic) stretch reflex or the H-reflex. The stretch reflex, a rapid excitatory response of a muscle following stretch, is a complex muscle reaction consisting of multiple excitatory responses occurring at different latencies following muscle stretch, with the “short-latency” response being an involuntary (re)action that occurs in a matter of milliseconds following muscle stretch (eg, the latency time for a biceps brachii reflex is approximately 20 milliseconds following the onset of stretch).<sup>52,53</sup> The neural pathway mediating the short-latency stretch reflex consists primarily of a pathway with a single synapse in the spinal cord separating the Ia-afferent fiber from the homonymous  $\alpha$ -motoneuron.<sup>30,54,55</sup> The H-reflex, which is elicited by electrical stimulation of a peripheral nerve, activates the Ia-afferent nerve fibers from the muscle spindles

to produce a reflex contraction (Figure 3).<sup>56,57</sup> Howell et al<sup>4</sup> state the following:

The H-reflex is similar to the stretch reflex except for the fact that the H-reflex bypasses these muscle spindles, which serve to initiate the stretch reflex.<sup>58</sup> Because the H-reflex bypasses the spindles, it cannot be modulated by the gamma efferent system, which modulates the stretch reflex.<sup>59</sup> If an experimental or clinical intervention alters the stretch reflex, but not the H-reflex, alteration of spindle sensitivity is generally suggested, whereas if an intervention alters both reflexes, the mechanism is more likely to relate either to altered [ $\alpha$ -motoneuron] excitability or to altered presynaptic inhibition at Ia afferent fiber endings on the [ $\alpha$ -motoneurons]. With this stated the idea that the stretch reflex and H-reflex are identical, except for the participation of the spindles, has been in retreat in recent years.

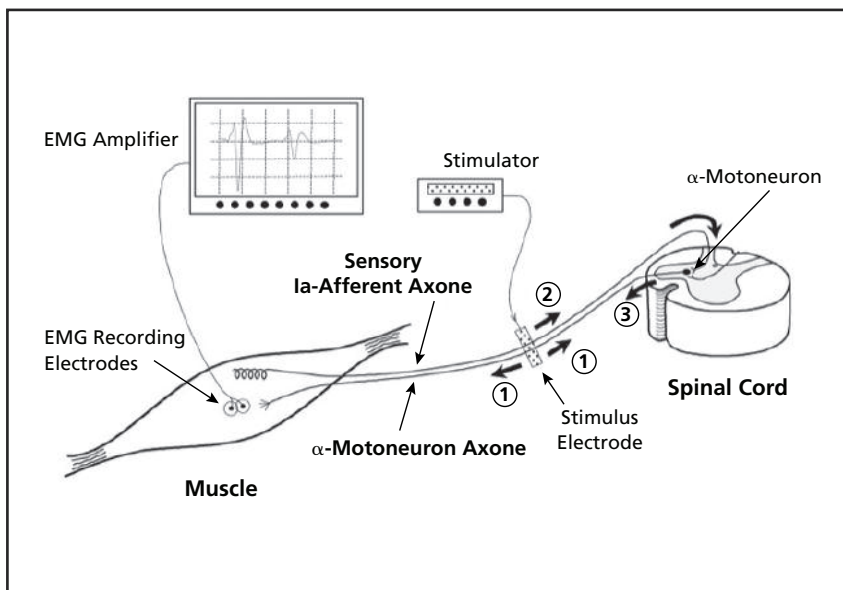
In this study,<sup>4</sup> the authors quantified the amplitude of the short-latency stretch reflex and H-reflex in the triceps surae muscles (ie, the soleus together with the lateral and medial heads of the gastrocnemius) in 16 patients with Achilles tendinitis both before and after a single strain-counterstrain session. Additionally, these measurements were also made in 15 asymptomatic control participants before and after sham manipulative treatment. The results, detailed in the

Table, revealed that the strain-counterstrain treatment produced a 23.1% decrease in the amplitude of the stretch reflex of the soleus ( $P < .05$ ) in patients with Achilles tendinitis. Similarly significant responses were observed in the stretch reflexes of the lateral and medial heads of the gastrocnemius muscles. The treatment did not alter the H-reflex. Additionally, subjective ratings of symptom severity (ie, soreness, stiffness, and swelling) were lower following treatment. In control participants, neither reflex was significantly affected by sham manipulative treatment.

In summary, the results of this study<sup>4</sup> indicated that the amplitude of the stretch reflex in patients with Achilles tendinitis decreased after strain-counterstrain manual therapy. This finding suggests that a single strain-counterstrain treatment reduces the excitability of the stretch reflex, which the authors postulated was because of the treatment decreasing nociceptor activity and subsequently decreasing the excitability of  $\gamma$ -motoneurons. Theoretically, a reduction in the overall excitability of the stretch reflex could lead to a reduced level of involuntary muscle activity. Indeed, the basic tenet of the pain-spasm-pain model is that pain will result in more sustained and increased muscle activation.<sup>19</sup> Here, the pain-spasm-pain model predicts that muscle activity levels will be high during submaximal tasks and under resting conditions. As such, the

authors of a follow-up study<sup>21</sup> (see study 2) sought to address this issue. Studies 1<sup>4</sup> and 4,<sup>51</sup> however, focused on identifying the mechanisms of manual therapies in the context of LBP. The key rationale for shifting focus to the mechanisms of manual therapies in LBP were as follows:

- 1. Low back pain is clinically significant.** One of the most common reasons for seeking medical care, LBP accounts for more than 3.7 million physician visits each year in the United States. Ninety percent of adults will experience LBP in their lifetime, 50% will experience recurrent LBP, and 10% will develop chronic pain and related disability.<sup>60-63</sup>
- 2. Low back pain is the most common reason for seeking manual therapies.** According to a 2007 national survey, more than 18 million US adults aged 18 years or older received manual therapies in 2007, at a total annual out-of-pocket cost of \$3.9 billion.<sup>64</sup> The most common reason for seeking these treatments was LBP.<sup>64</sup>



**Figure 3.** Schematic illustration of the Hoffmann-reflex (H-reflex) neural pathway. When the peripheral nerve is electrically stimulated (1), action potentials are elicited selectively in the axons of the sensory Ia afferents because of their large axone diameter (2). The evoked action potentials propagate to the spinal cord, where they give rise to excitatory postsynaptic potentials, in turn eliciting action potentials that travel in the  $\alpha$ -motoneuron axones toward the muscle (3). Subsequently, following a brief latency, the volley of afferent action potentials is recorded in the muscle as an H-reflex. **Abbreviation:** EMG, electromyogram. Reprinted from Aagaard et al<sup>67</sup> with permission from The American Physiological Society.

**3. Manual therapies are effective in reducing LBP and disability.** During the past decade, there has been growing scientific evidence supporting the clinical effectiveness of manual therapies for LBP.<sup>65-72</sup>

Moreover, the pain-spasm-pain cycle has been postulated in the etiologic process of LBP,<sup>19</sup> and as such, we believe that LBP not only serves as a great model to study the mechanistic effects of manual therapies, but also that understanding the mechanisms in the context of LBP will inform and impact the way practitioners use manual therapies in clinical practice.

### Study 2. Muscle functional magnetic resonance imaging and acute LBP<sup>21</sup>

In this study, Clark et al<sup>21</sup> sought to determine whether patients with acute LBP exhibited differences in their levels of resting trunk muscle activity compared with healthy, asymptomatic controls. The authors also sought to determine if a single treatment session of OMT alters the level of resting muscle activity. They wrote the following<sup>21</sup>:

Numerous studies have utilized electromyography (EMG), mainly surface EMG, to examine whether patients with LBP exhibit differences in their muscle activation patterns under resting conditions, with the majority not observing differences between patients with LBP and controls,<sup>73-77</sup> although some have observed differences.<sup>78</sup> Unfortunately, technical limitations of surface EMG, such as the attenuation in the myoelectric signal attributed to subcutaneous tissue and ... crosstalk among muscles—have limited the ability to precisely quantify and localize the muscle activity of specific lumbar muscles.<sup>79,80</sup> [MRI], on the other hand, possesses outstanding spatial resolution that allows for the investigation of individual muscles. Muscle functional MRI allows noninvasive measurement of the metabolic and hemodynamic responses of skeletal muscle by observing changes in the contrast properties of certain MR images that occur in skeletal muscle with activity.<sup>81-83</sup> Specifically, mfMRI measures the transverse relaxation time (T2) of skeletal muscle protons and allows for determination of the spatial pattern of muscle activation.<sup>81-83</sup> Muscle activity has been shown to increase T2, with T2 changes within a muscle being sensitive to as few as 2 repetitions of resistance exercise<sup>84</sup> and strongly related to the magnitude of isometric torque produced by skeletal muscle.<sup>85</sup>

Accordingly, the authors used mfMRI to gain insight into whether manual therapies affect resting activation patterns of the trunk muscles.

Nine patients with nonspecific acute LBP (mean [standard deviation (SD)] score on a 0 to 10–point visual analog

**Table.**  
Normalized Stretch Reflex and H-Reflex Amplitudes for Triceps Surae Muscles in Patients With Achilles Tendinitis Before and After a Single Strain-Counterstrain Manual Therapy Treatment (n=16)

Muscle	Stretch Reflex <sup>a</sup>			H-Reflex <sup>a</sup>		
	Before	After	Change, % <sup>b</sup>	Before	After	Change, %
Soleus	0.078	0.062	-23.08	0.500	0.485	-3.17
M. gastrocnemius	0.043	0.036	-18.30	0.278	0.261	6.43
L. gastrocnemius	0.025	0.019	-25.73	0.185	0.168	-9.31

<sup>a</sup> The respective reflex values were expressed as the ratio of measured reflex amplitude relative to the maximum M-wave amplitude evoked by means of supramaximal electrical stimulation in the same subject.

<sup>b</sup> Significant differences between pre-treatment and post-treatment stretch reflexes were noted for all 3 muscles ( $P < .05$ ). No significant differences were noted between pretreatment and post-treatment H-reflexes.

**Abbreviations:** H-reflex, Hoffmann-reflex; M. gastrocnemius, medial gastrocnemius; L. gastrocnemius, lateral gastrocnemius.

scale, 3.02 [2.81]) and 9 age- and sex-matched asymptomatic controls participated in this study. All participants underwent MRI, and subsequently the patients with LBP received a single session of OMT and then underwent another MRI. The LBP participants reported back for an additional MRI 48 hours following their initial visit. The MRI data were used to calculate T2 and T2 asymmetry (ie, side-to-side differences) as an index of muscle activity from regions of interest in the psoas, quadratus lumborum, multifidus, and iliocostalis lumborum/longissimus thoracis muscles. Results indicated that there were no differences between the LBP patients and healthy controls when T2 was averaged for the left- and right-sided muscles. However, the quadratus lumborum muscle showed a significantly greater mean (SD) T2 asymmetry in patients with acute LBP compared with controls (29.1% [4.3%] vs 15.9% [4.1%];  $P = .05$ ) (Figure 4). The psoas muscle also displayed a relatively large, albeit nonsignificant, mean difference (22.7% [6.9%] vs 9.5% [2.8%];  $P = .11$ ). In the patients with LBP, psoas T2 asymmetry was significantly reduced immediately after the OMT (25.3% [6.9%] to 6.1% [1.8%],  $P = .05$ ) (Figure 4), and the change in pain immediately following treatment was correlated with the change in psoas T2 asymmetry ( $r = 0.75$ ,  $P = .02$ ). The side exhibiting the greater baseline T2 value exhibited the greatest reduction in T2 activity, whereas the side with the lower baseline T2 value seemed to increase slightly. In Figure 5, 3 MRI images illustrate the differences in T2 asymmetry patterns between a healthy control patient and a patient with LBP, including the changes following OMT.

In summary, the authors observed that OMT decreased T2 asymmetry with the most notable reduction occurring in the psoas muscle. Additionally, the side with the higher T2 at baseline was reduced following treatment, and the normalization of the T2 asymmetry was associated with

## BRIEF REPORT

reduced pain. It has long been postulated that the mechanism(s) of manual therapies are related to an attenuation of the excitability of the muscle spindle afferents that reduces reflexive contractile activity.<sup>4,7</sup> Thus, while these data alone do not provide insight into specific neurologic mechanisms of manual therapies, they do suggest that in patients with acute LBP, manual therapies may function to normalize psoas muscle activity by reducing the activity in the hyperactive side and presumably disrupt the pain-spasm-pain cycle. The 2 most recent studies<sup>25,51</sup> in this series (see studies 3 and 4) expanded on these findings by trying to identify the neurophysiologic effects of 2 different types of manual therapies (ie, thrust-based and non-thrust-based manual therapies) on the erector spinae muscles.

### Study 3. Neurophysiologic effects of spinal manipulation in patients with chronic LBP<sup>25</sup>

In this study,<sup>25</sup> the authors examined the neurophysiologic effects of a single HVLA spinal manipulation thrust to determine whether these physiologic responses were dependent on HVLA spinal manipulation causing an audible joint sound. They wrote as follows<sup>25</sup>:

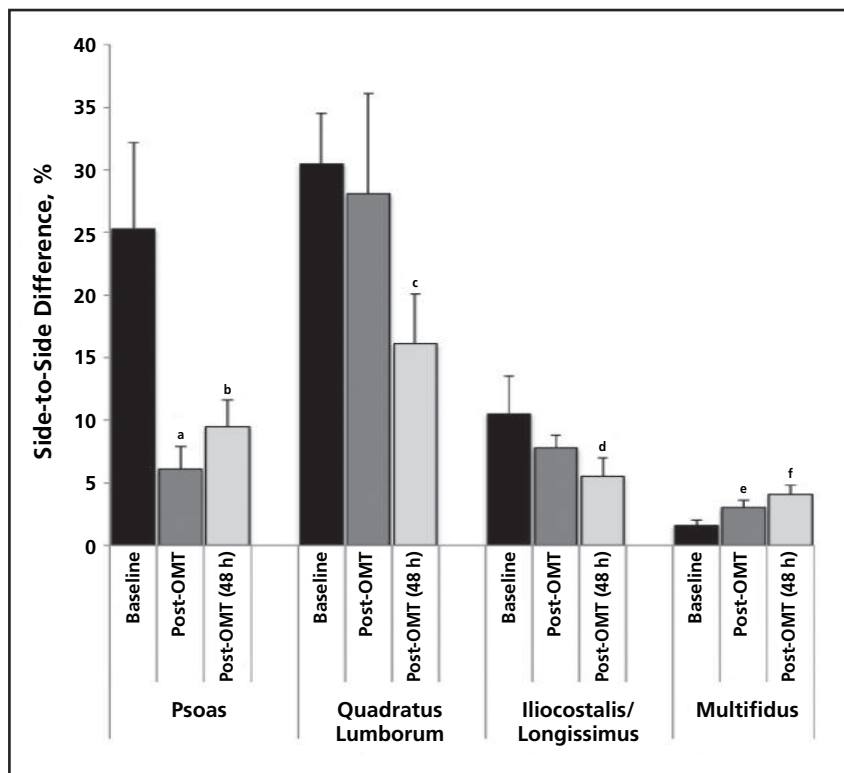
The scientific understanding of the neurophysiologic characteristics of the human low back muscles has historically been hindered by the lack of experimental techniques to examine these muscles' function *in vivo*. However, in recent years innovative advancements in neurophysiologic assess-

ment techniques—such as transcranial magnetic stimulation (TMS) to elicit motor evoked potentials (MEP)<sup>3,86-88</sup> and mechanically elicited stretch reflexes<sup>50,86,87</sup>—have begun to be applied to the study of the human lumbar musculature.

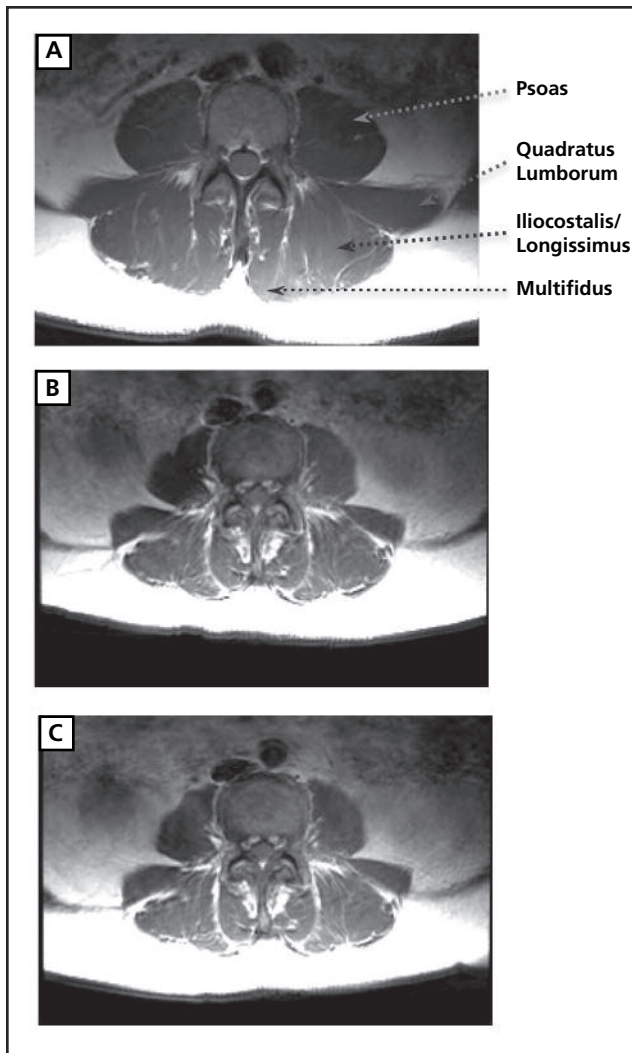
We previously demonstrated the reliability and stability of these measures serially.<sup>86</sup> The authors used these neurophysiologic techniques to determine the effects of a single HVLA spinal manipulation thrust on corticospinal and stretch reflex excitability in patients with chronic LBP and healthy participants. Further, the authors stated the following<sup>25</sup>:

In addition to determining whether the MEP and stretch reflex amplitude were different in individuals with and without LBP, we also examined whether these physiologic responses depended on whether the HVLA spinal manipulation caused an audible sound from the joint (ie, the pop or cracking sound that one often associates with joint manipulations). The role of the audible response in determining treatment effects has long been a matter of intense debate. Some studies have previously reported that an audible response is not necessary to improve clinical outcomes.<sup>89,90</sup>

Some have reported that biomechanical effects (eg, increased joint laxity, motion, and gapping) are contingent on manipulation resulting in an audible sound.<sup>91,92</sup> To date, however, few studies have investigated whether the phys-



**Figure 4.** Changes in transverse relaxation time ( $T_2$ ) asymmetry in patients with acute low back pain after a single osteopathic manipulative treatment (OMT) session. Data were obtained before treatment (baseline), immediately after OMT, and 48 hours after OMT. Value of  $T_2$  asymmetry was calculated as the absolute value of the percent difference in magnetic resonance imaging–derived  $T_2$  between the left- and right-sided muscles. Immediately after OMT, the  $T_2$  asymmetry in the psoas muscle was reduced, but it returned to baseline levels after 48 hours, although a modest effect size was still observed. Conversely, 48 hours after OMT, a small but significant increase in multifidus  $T_2$  asymmetry was observed. The quadratus lumborum and iliocostalis/longissimus muscles exhibited modest effect sizes for reduced  $T_2$  asymmetry associated with OMT, although these differences failed to reach statistical significance. <sup>a</sup> $P=.05$ ,  $\eta^2=0.42$ . <sup>b</sup> $P=.06$ ,  $\eta^2=0.41$ . <sup>c</sup> $P=.23$ ,  $\eta^2=0.19$ . <sup>d</sup> $P=.27$ ,  $\eta^2=0.17$ . <sup>e</sup> $P=.15$ ,  $\eta^2=0.19$ . <sup>f</sup> $P=.01$ ,  $\eta^2=0.67$ . Reprinted from Clark et al.<sup>21</sup>



**Figure 5.** Transaxial magnetic resonance images of a 69-year-old woman without back pain (A) and a 69-year-old woman with acute low back pain before (B) and immediately after (C) osteopathic manipulative treatment. These images of the L3-L4 region illustrate the spatial orientation of the psoas, quadratus lumborum, iliocostalis lumborum/longissimus thoracis, and multifidus muscles. Ten-millimeter thick transaxial images were obtained from the lumbar region with a 2000-millisecond repetition time, 30-millisecond and 65-millisecond echo times, and a 10-mm slice-to-slice interval. These derived images were used to calculate the transverse relaxation time ( $T_2$ ) and allow for a noninvasive measurement of the metabolic and hemodynamic responses of skeletal muscle in association with muscle activity. Note the similar signal intensity in the left and right lumbar muscles of the control subject (A), the asymmetry in the psoas and quadratus lumborum muscles before treatment (B), and the attenuation of this asymmetry immediately after treatment (C). Reprinted from Clark et al.<sup>21</sup>

ologic response is dependent on the manipulation causing an audible joint sound.

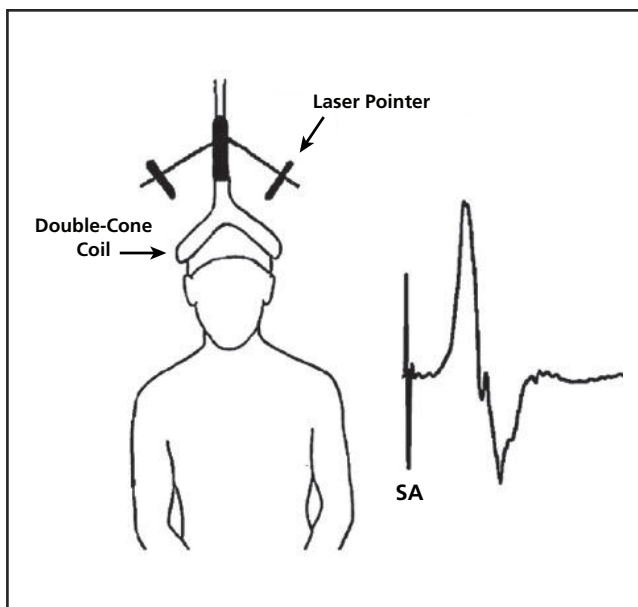
Ten patients with chronic LBP—defined by usual rating of mean (SD) 4.0 (1.2) on a 0 to 10 visual analog scale—and 10 age-, sex-, and body mass index-matched asymptomatic control participants were enrolled in this study. The effects of a single HVLA spinal manipulation thrust on MEP and short-latency stretch reflex amplitude of the erector spinae muscles were assessed before and approximately 10 minutes after treatment (Figure 6 and Figure 7). The results, expressed as mean (SD), indicated that HVLA spinal manipulation did not alter the erector spinae MEP amplitude in patients with chronic LBP (0.80 [0.33] to 0.80 [0.30]  $\mu$ V) or in asymptomatic controls (0.56 [0.09] to 0.57 [0.06]  $\mu$ V). Similarly, HVLA spinal manipulation did not alter the erector spinae stretch reflex amplitude in patients with chronic LBP (0.66 [0.12] to 0.66 [0.15]  $\mu$ V) or in asymptomatic controls (0.60 [0.09] to 0.55 [0.08]  $\mu$ V). Interestingly, study participants whose treatment pro-

duced an audible response (regardless of whether they had LBP) exhibited a 20% decrease in the stretch reflex but no change in the MEP amplitude (Figure 8).

In summary, the authors observed that a single HVLA spinal manipulation treatment did not systematically alter MEP or short-latency stretch reflex amplitude of the erector spinae muscles in patients with chronic LBP or asymptomatic controls, at least when assessed approximately 10 minutes after treatment. However, when the authors looked at the data regarding whether HVLA spinal manipulation caused an audible joint sound, they observed that study participants exhibiting an audible response exhibited a substantial reduction in the short-latency stretch reflex regardless of patient group. This finding provides further insight into the mechanisms of action of manual therapies and suggests that in certain cases they act by down-regulating the excitability of the muscle spindles or the various segmental sites of the Ia-reflex pathway. The follow-up investigation<sup>51</sup> (study 4) focused on examining the effects of nonthrust manual therapy on changes in the short-latency stretch reflex.

#### **Study 4. Nonthrust manual therapy reduces erector spinae short-latency stretch reflex asymmetries in patients with chronic LBP<sup>51</sup>**

The purpose of this study<sup>51</sup> was to determine if nonthrust manual therapy attenuates the short-latency stretch reflex of the erector spinae muscles in patients with chronic LBP. Nine subjects with chronic LBP—defined by usual LBP rating of mean (SD) 3.7 (0.5) on a 0 to 10-point visual analog scale—participated in this study. The effects of a single session of nonthrust manual therapy on the short-latency stretch reflex amplitude were assessed before and approximately 10 minutes after treatment. The nonthrust manual therapy procedures consisted of a com-

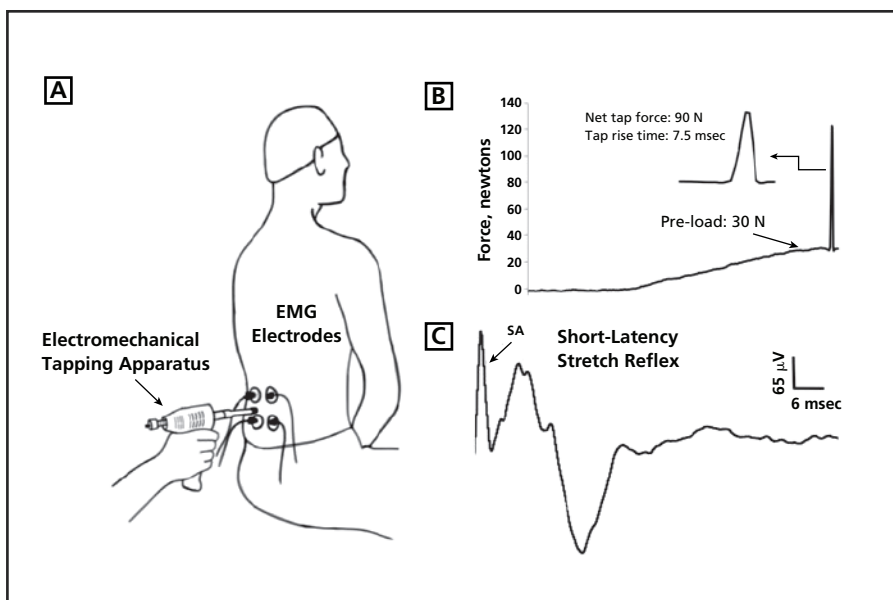


**Figure 6.** The experimental setup for performing transcranial magnetic stimulation to evoke motor-evoked potentials from the erector spinae muscles. A representative motor potential recorded from the erector spinae muscles is illustrated on the right. **Abbreviation:** SA, stimulus artifact. Reprinted from Goss et al<sup>86</sup> with permission from Elsevier.

combination of 3 common non-thrust-based techniques commonly used to treat LBP: muscle energy, myofascial release, and strain-counterstrain. The results indicated that the patients with LBP exhibited a large asymmetry in the short-latency stretch reflex at baseline (prior to

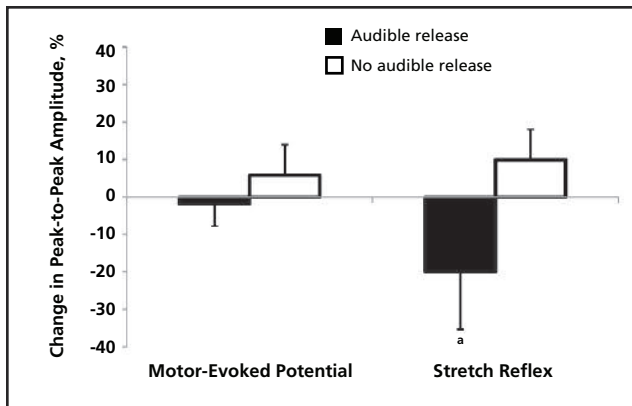
treatment), with the higher of the paraspinal sides exhibiting a mean (SD) 100.2% (28.2%) greater value than the lower side. After the nonthrust manual therapy, stretch reflex asymmetry was reduced (100.2 [28.2%] to 36.6% [23.1%];  $P=.03$ ) (Figure 9). This change was largely due to a reduced stretch reflex amplitude on the side that was higher at baseline (35% reduction following treatment;  $P=.05$ ), whereas no change over time was observed in the low side ( $P=.23$ ) (Figure 10). Additionally, there was no difference between the respective sides following the intervention ( $P=.38$ ), indicating that the asymmetry was normalized after treatment.

These findings provide insight into the mechanisms of action of nonthrust manual therapy and—as with the aforementioned work on HVLA manual therapy—suggest that manual therapies in certain instances act by down-regulating the excitability of the muscle spindles or the various segmental sites of the Ia-reflex pathway. One limitation of studies 3 and 4, which observed changes in excitability for erector spinae stretch reflex was the inability of the authors to distinguish changes in spindle sensitivity from the Ia-reflex pathway (as we described previously in the discussion relating to study 1).<sup>4</sup> Unfortunately, the anatomy of the erector spinae muscles made it technically difficult (if not impossible) to elicit readings of H-reflexes from this muscle group. Unlike the case with the triceps surae in study 1, the authors could not definitively identify which anatomic substrate or segmental site was the source of observed changes. In the next section, we collectively interpret the findings from the recent studies and provide our perspectives on key questions and issues that need to be addressed in the future to vertically advance our understanding and clinical use of manual therapies.



**Figure 7.** Depiction of the experimental setup for evoking short-latency stretch reflexes from the lumbar paraspinal muscles. The tip of an electromechanical tapping apparatus is gradually pressed into the erector spinae tissue (A) until a pre-loaded force of 30 N is reached, after which a rapid mechanical tap to the muscle with a net force of 90 N is delivered (B). A representative example of a short-latency stretch reflex is then recorded from the erector spinae muscles in response to the mechanical tap (C). **Abbreviations:** EMG, electromyogram; SA, stimulus artifact. Reprinted from Goss et al<sup>86</sup> with permission from Elsevier.





**Figure 8.** Amplitudes of motor-evoked potential and stretch reflex in patients with low back pain and asymptomatic patients undergoing spinal manipulation. High-velocity, low-amplitude spinal manipulation did not significantly alter the amplitude of the motor-evoked potential recorded from the erector spinae muscles regardless of whether spinal manipulation produced an audible response. Interestingly, spinal manipulation significantly reduced the amplitude of the short-latency stretch reflex regardless of audible response. <sup>a</sup>Time × group interaction;  $P < .05$ . Reprinted from Clark et al.<sup>25</sup>

### Conceptual Model on the Mechanisms of Manual Therapies and Perspectives

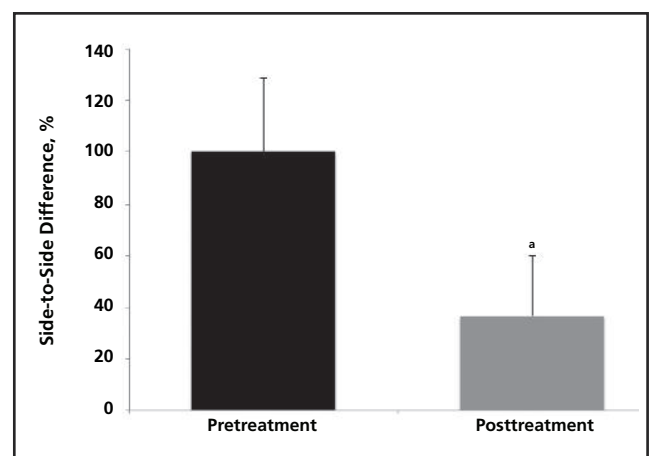
The series of studies summarized in this article provide consistent evidence suggesting that a single manual therapy reduces the sensitivity of the muscle spindles to stretch. In Figure 11, we present our working conceptual model on the pain-spasm-pain cycle (Figure 11A), as well as an integrated model where we postulate on how manual therapies act to disrupt the pain-spasm-pain cycle (Figure 11B). Specifically, in Figure 11A, we postulate that musculoskeletal pain conditions (eg, LBP) are associated with heightened levels of nociceptive input arising from damaged tissues, such as skeletal muscle (eg, class III and IV afferents), tendons, ligaments, bone, and annulus fibrosus. We postulate that this increased nociceptive input increases excitatory input to the  $\gamma$ -motoneurons, which increases the excitability of the muscle spindle and results in increased muscle spindle-afferent activity, particularly in response to stretch or changes in muscle length. This heightened level of muscle spindle-afferent activity, along with heightened level of nociceptive input, would theoretically result in the pool of  $\alpha$ -motoneurons receiving greater excitatory input. This increased level of excitatory input could result in involuntary activation of  $\alpha$ -motoneurons and muscle fibers (ie, spasm), or a greater probability of  $\alpha$ -motoneurons discharging with lower levels of descending supraspinal input (or excitatory input from any source). Ultimately, the end-organ effect would increase muscle activity, which could further exacerbate nociceptive input and, in turn, the pain-spasm-pain cycle.

We postulate that manual therapies function, at least in part, by attenuating nociceptive input, which in turn reduces excitatory input to the  $\gamma$ -motoneurons, thereby normalizing the excitability of the stretch reflex (Figure 11B). This decreased stretch reflex response, coupled with the reduced nociceptive input, would lessen excitatory input to the  $\alpha$ -motoneuron pool, ultimately decreasing muscle activity. Further, this series of events could also help to restore motion to affected tissues because the attenuated stretch reflex response may lessen the likelihood or severity of reflexive involuntary contractions that may occur with functional movements. Figure 11 pools data from studies 1, 3, and 4 to support the notion that manual therapies act to reduce the excitability of the muscle spindles (as we have observed by means of a consistent decrease in the short-latency stretch reflex response). Data from study 2 show that manual therapies also reduce the activity of hyperactive skeletal muscles.

Our conceptual model on the mechanisms of manual therapies is far from complete, and further work is needed to address several key questions. From a basic science mechanistic perspective, there are several key questions that need to be addressed, for example:

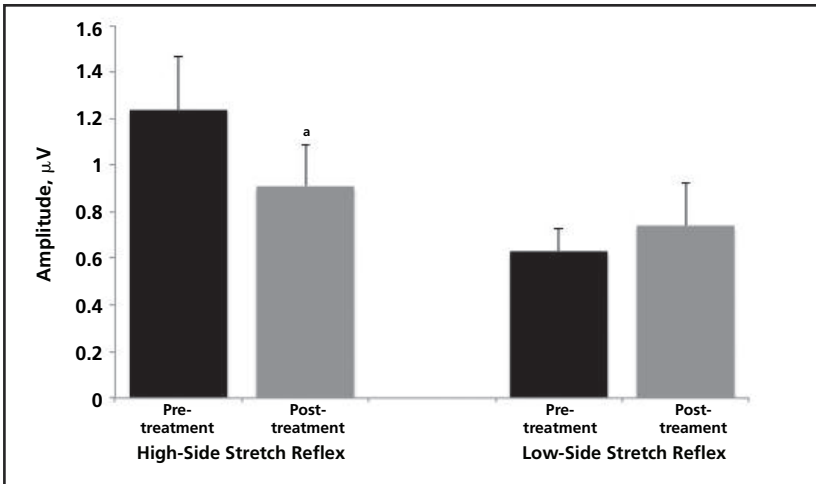
- Do manual therapies alter nociceptive processing and, if so, in what way?
- Do manual therapies exert effects on higher brain centers and, if so, in what way?
- Do different types of manual therapies (eg, thrust-based vs non-thrust-based) have different mechanistic actions (eg, exert effects directly on muscle spindle sensitivity independent of nociceptive mediators)?

Answers to these questions would provide critical insight on the biological effects of manual therapies. From a trans-

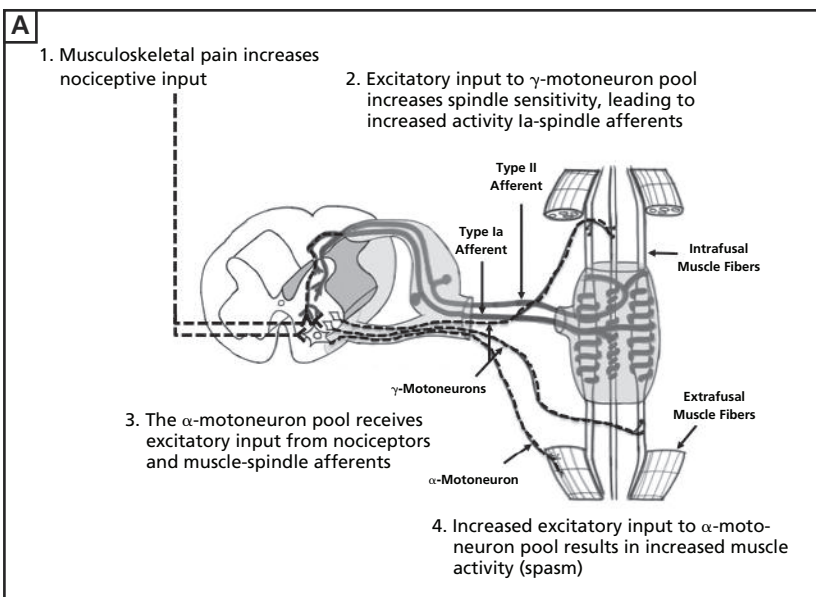


**Figure 9.** Rates of asymmetry in patients with low back pain ( $N=9$ ) before and after nonthrust manual therapy. Treatment attenuated short-latency stretch reflex asymmetry in the erector spinae muscles. <sup>a</sup> $P=.03$ . Reprinted from Goss et al<sup>52</sup> with permission from Elsevier.

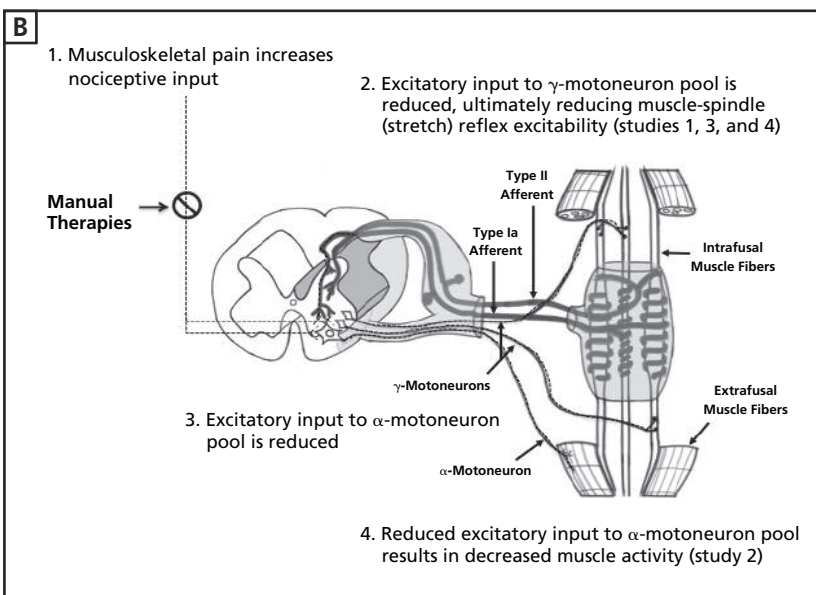
## BRIEF REPORT



**Figure 10.** Short-latency stretch reflex reductions in patients with low back pain (N=9) treated with nonthrust manual therapy. Treatment affected the side with the higher stretch reflex amplitude at baseline without affecting the side with the lower stretch reflex amplitude at baseline. <sup>a</sup>P=.05. Reprinted from Goss et al<sup>12</sup> with permission from Elsevier.



**Figure 11.** Conceptual model of the pain-spasm-pain cycle (A) and conceptual model of manual therapies disrupting the pain-spasm-pain cycle (B). In panel A, musculoskeletal pain (eg, low back pain) causes increased levels of nociceptive input when tissues such as muscles, tendons, or bones are damaged (1). The increased nociceptive input transmits excitatory input to the  $\gamma$ -motoneurons (2), which increases the excitability of muscle spindle and muscle spindle afferents, particularly in response to stretch or changes in muscle length. Heightened levels of nociceptive input and afferent activity would then transmit excitatory input to  $\alpha$ -motoneurons (3), resulting in involuntary activation (ie, spasm) or involuntary discharge of  $\alpha$ -motoneurons caused by lower levels of excitatory input from other sources (eg, descending input) (4). Ultimately, the end-organ effect would be increased muscle activity, which could further exacerbate nociceptive input and, in turn, the pain-spasm-pain cycle. In panel B, we postulate that manual therapies function by attenuating nociceptive input (1), which in turn reduces excitatory input to the  $\gamma$ -motoneurons, thereby normalizing the excitability of the stretch reflex (2). This decreased stretch reflex response, coupled with the reduced nociceptive input, would result in less excitatory input to  $\alpha$ -motoneuron pools (3), ultimately decreasing muscle activity (4). Data from studies 1, 3, and 4 support the theory that manual therapies act to reduce the excitability of the muscle spindles, and data from study 2 support the theory that manual therapies reduce the hyperactivity of skeletal muscles.



lational science perspective, we still need to better define and understand the timing of biological effects of manual therapy, as well as investigate longer-term courses of treatments (eg, Do multiple treatments result in additive effects?). Subsequent studies will, in the long term, assist in optimizing the frequency and duration of manual therapies. Lastly, clinical prediction rules for the use of manual therapies need to be developed and refined. Recent efforts on this front have been productive,<sup>93-99</sup> but more work is certainly needed to better identify which individuals are most likely to benefit from various types of manual therapy interventions.

## Conclusion

Our work over the past 5 years has focused on the mechanistic effects of manual therapies. Specifically, we have tested hypotheses centered on whether manual therapies play a role in disrupting the pain-spasm-pain cycle. Collectively, the evidence from these studies suggests that manual therapies act to disrupt the pain-spasm-pain cycle.

## References

- Clark BC, Walkowski S, Conatser RR, Eland DC, Howell JN. Muscle functional magnetic resonance imaging and acute low back pain: a pilot study to characterize lumbar muscle activity asymmetries and examine the effects of osteopathic manipulative treatment. *Osteopath Med Prim Care*. 2009;3:7.
- Côté P, Mior SA, Vernon H. The short-term effect of a spinal manipulation on pain/pressure threshold in patients with chronic mechanical low back pain. *J Manipulative Physiol Ther*. 1994;17(6):364-368.
- Dishman JD, Greco DS, Burke JR. Motor-evoked potentials recorded from lumbar erector spinae muscles: a study of corticospinal excitability changes associated with spinal manipulation. *J Manipulative Physiol Ther*. 2008;31(4):258-270.
- Howell JN, Cabell KS, Chila AG, Eland DC. Stretch reflex and Hoffmann reflex responses to osteopathic manipulative treatment in subjects with Achilles tendinitis. *J Am Osteopath Assoc*. 2006;106(9):537-545.
- Johansson H, Sojka P. Pathophysiological mechanisms involved in genesis and spread of muscular tension in occupational muscle pain and in chronic musculoskeletal pain syndromes: a hypothesis. *Med Hypotheses*. 1991;35(3):196-203.
- Knutson GA. The role of the gamma-motor system in increasing muscle tone and muscle pain syndromes: a review of the Johansson/Sojka hypothesis. *J Manipulative Physiol Ther*. 2000;23(8):564-572.
- Korr IM. Proprioceptors and somatic dysfunction. *J Am Osteopath Assoc*. 1975;74(7):638-650.
- Matre DA, Sinkjaer T, Svensson P, Arendt-Nielsen L. Experimental muscle pain increases the human stretch reflex. *Pain*. 1998;75(2-3):331-339.
- Pickar JG. Neurophysiological effects of spinal manipulation. *Spine J*. 2002;2(5):357-371.
- Terrett AC, Vernon H. Manipulation and pain tolerance: a controlled study of the effect of spinal manipulation on paraspinal cutaneous pain tolerance levels. *Am J Phys Med*. 1984;63(5):217-225.
- Vernon HT, Aker P, Burns S, Viljakaenen S, Short L. Pressure pain threshold evaluation of the effect of spinal manipulation in the treatment of chronic neck pain: a pilot study. *J Manipulative Physiol Ther*. 1990;13(1):13-16.
- Pickar JG, Kang YM. Paraspinal muscle spindle responses to the duration of a spinal manipulation under force control. *J Manipulative Physiol Ther*. 2006;29(1):22-31.
- Pickar JG, McLain RF. Responses of mechanosensitive afferents to manipulation of the lumbar facet in the cat. *Spine (Phila Pa 1976)*. 1995;20(22):2379-2385.
- Pickar JG, Sung PS, Kang YM, Ge W. Response of lumbar paraspinal muscles spindles is greater to spinal manipulative loading compared with slower loading under length control. *Spine J*. 2007;7(5):583-595.
- Pickar JG, Wheeler JD. Response of muscle proprioceptors to spinal manipulative-like loads in the anesthetized cat. *J Manipulative Physiol Ther*. 2001;24(1):2-11.
- Sung PS, Kang YM, Pickar JG. Effect of spinal manipulation duration on low threshold mechanoreceptors in lumbar paraspinal muscles: a preliminary report. *Spine (Phila Pa 1976)*. 2005;30(1):115-122.
- Bialosky JE, Bishop MD, Price DD, Robinson ME, George SZ. The mechanisms of manual therapy in the treatment of musculoskeletal pain: a comprehensive model. *Man Ther*. 2009;14(5):531-538.
- Travell J, Rinzler S, Herman M. Pain and disability of the shoulder and arm. *JAMA*. 1942;120(6):417-422.
- van Dieën JH, Selen LP, Cholewicki J. Trunk muscle activation in low-back pain patients: an analysis of the literature. *J Electromyogr Kinesiol*. 2003;13(4):333-351.
- Lehman GJ, McGill SM. Spinal manipulation causes variable spine kinematic and trunk muscle electromyographic responses. *Clin Biomech (Bristol, Avon)*. 2001;16(4):293-299.
- Clark BC, Walkowski S, Conatser RR, Eland DC, Howell JN. Muscle functional magnetic resonance imaging and acute low back pain: a pilot study to characterize lumbar muscle activity asymmetries and examine the effects of osteopathic manipulative treatment. *Osteopath Medicine Prim Care*. 2009;3:7.
- Colloca CJ, Keller TS. Stiffness and neuromuscular reflex response of the human spine to posteroanterior manipulative thrusts in patients with low back pain. *J Manipulative Physiol Ther*. 2001;24(8):489-500.
- Ferreira ML, Ferreira PH, Hodges PW. Changes in postural activity of the trunk muscles following spinal manipulative therapy. *Man Ther*. 2007;12(3):240-248.
- Bicalho E, Setti JA, Macagnan J, Cano JL, Manfrea EF. Immediate effects of a high-velocity spine manipulation in paraspinal muscles activity of nonspecific chronic low-back pain subjects. *Man Ther*. 2010;15(5):469-475.
- Clark BC, Goss DA Jr, Walkowski S, Hoffman RL, Ross A, Thomas JS. Neurophysiologic effects of spinal manipulation in patients with chronic low back pain. *BMC Musculoskelet Disord*. 2011;12:170.
- Duval C, Lafontaine D, Hébert J, Leroux A, Panisset M, Boucher JP. The effect of Trager therapy on the level of evoked stretch responses in patients with Parkinson's disease and rigidity. *J Manipulative Physiol Ther*. 2002;25(7):455-464.
- Newham DJ, Lederman E. Effect of manual therapy techniques on the stretch reflex in normal human quadriceps. *Disabil Rehabil*. 1997;19(8):326-331.
- Dishman JD, Bulbulian R. Spinal reflex attenuation associated with spinal manipulation. *Spine (Phila Pa 1976)*. 2000;25(19):2519-2525.
- Hoffmann P. Beiträge zur Kenntnis der menschlichen Reflexe mit besonderer Berücksichtigung der elektrischen Erscheinungen. *Arch Anat Physiol*. 1910:223-246.
- Liddell EGT, Sherrington C. Reflexes in response to stretch (myotatic reflexes). *Proc R Soc London B*. 1924;96B:212-242.
- Allen TJ, Proske U. Effect of muscle fatigue on the sense of limb position and movement. *Exp Brain Res*. 2006;170(1):30-38.
- Ansems GE, Allen TJ, Proske U. Position sense at the human forearm in the horizontal plane during loading and vibration of elbow muscles. *J Physiol*. 2006;576(pt 2):445-455.
- Gooley K, Bradfield O, Talbot J, Morgan DL, Proske U. Effects of body orientation, load and vibration on sensing position and movement at the human elbow joint. *Exp Brain Res*. 2000;133(3):340-338.
- Proske U, Gandevia SC. The kinaesthetic senses. *J Physiol*. 2009;587(pt 17):4139-4146.
- Rossi-Durand C. Proprioception and myoclonus. *Neurophysiol Clin*. 2006;36(5-6):299-308.
- Kandel ER, Schwartz JH, Jessell TM. *Principles of Neural Science*. 4th ed. New York, NY: McGraw-Hill; 2000.

(continued)

## BRIEF REPORT

37. Djupsjöbacka M, Johansson H, Bergenheim M. Influences on the gamma-muscle-spindle system from muscle afferents stimulated by increased intramuscular concentrations of arachidonic acid. *Brain Res*. 1994;663(2):293-302.
38. Djupsjöbacka M, Johansson H, Bergenheim M, Sjolander P. Influences on the gamma-muscle-spindle system from contralateral muscle afferents stimulated by KCl and lactic acid. *Neurosci Res*. 1995;21(4):301-309.
39. Djupsjöbacka M, Johansson H, Bergenheim M, Wenggren BI. Influences on the gamma-muscle spindle system from muscle afferents stimulated by increased intramuscular concentrations of bradykinin and 5-HT. *Neurosci Res*. 1995;22(3):325-333.
40. Hellstrom F, Thunberg J, Bergenheim M, Sjölander P, Pedersen J, Johansson H. Elevated intramuscular concentration of bradykinin in jaw muscle increases the fusimotor drive to neck muscles in the cat. *J Dent Res*. 2000;79(10):1815-1822.
41. Wenggren BI, Pedersen J, Sjölander P, Bergenheim M, Johansson H. Bradykinin and muscle stretch alter contralateral cat neck muscle spindle output. *Neurosci Res*. 1998;32(2):119-129.
42. Thunberg J, Hellström F, Sjölander P, Bergenheim M, Wenggren B, Johansson H. Influences on the fusimotor-muscle spindle system from chemosensitive nerve endings in cervical facet joints in the cat: possible implications for whiplash induced disorders. *Pain*. 2001;91(1-2):15-22.
43. Hellström F, Thunberg J, Bergenheim M, et al. Increased intra-articular concentration of bradykinin in the temporomandibular joint changes the sensitivity of muscle spindles in dorsal neck muscles in the cat. *Neurosci Res*. 2002;42(2):91-99.
44. Kang YM, Wheeler JD, Pickar JG. Stimulation of chemosensitive afferents from multifidus muscle does not sensitize multifidus muscle spindles to vertebral loads in the lumbar spine of the cat. *Spine*. 2001;26(14):1528-1536.
45. Mense S. Nervous outflow from skeletal muscle following chemical noxious stimulation. *J Physiol*. 1977;267(1):75-88.
46. Svensson P, Wang K, Arendt-Nielsen L, Cairns BE. Effects of NGF-induced muscle sensitization on proprioception and nociception. *Exp Brain Res*. 2008;189(1):1-10.
47. Matre DA, Sinkjaer T, Knardahl S, Andersen JB, Arendt-Nielsen, L. The influence of experimental muscle pain on the human soleus stretch reflex during sitting and walking. *Clin Neurophysiol*. 1999;110(12):2033-2043.
48. Svensson P, Macaluso GM, De Laat A, Wang K. Effects of local and remote muscle pain on human jaw reflexes evoked by fast stretches at different clenching levels. *Exp Brain Res*. 2001;139(4):495-502.
49. Zedka M, Prochazka A, Knight B, Gillard D, Gauthier M. Voluntary and reflex control of human back muscles during induced pain. *J Physiol*. 1999;520(pt 2):591-604.
50. Birznies I, Burton AR, Macefield VG. The effects of experimental muscle and skin pain on the static stretch sensitivity of human muscle spindles in relaxed leg muscles. *J Physiol*. 2008;586(pt 11):2713-2723.
51. Goss DA Jr, Thomas JS, Walkowski S, et al. Non-thrust manual therapy reduces erector spinae short-latency stretch reflex asymmetries in patients with chronic low back pain [published online ahead of print January 20, 2012]. *J Electromyogr Kinesiol*.
52. Hammond PH. The influence of prior instruction to the subject on an apparently involuntary neuro-muscular response. *J Physiology*. 1956;132(1):17-8P.
53. Marsden CD, Merton PA, Morton HB. Servo action in human voluntary movement. *Nature*. 1972;238(5360):140-143.
54. Magladery JW, Porter WE, Park AM, Teasdale RD. Electrophysiological studies of nerve and reflex activity in normal man, IV: The two-neurone reflex and identification of certain action potentials from spinal roots and cord. *Bull Johns Hopkins Hosp*. 1951;88(6):499-519.
55. Burke D, Gandevia SC, McKeon B. Monosynaptic and oligosynaptic contributions to human ankle jerk and H-reflex. *J Neurophysiol*. 1984;52(3):435-448.
56. Schieppati M. The Hoffmann reflex: a means of assessing spinal reflex excitability and its descending control in man. *Prog Neurobiol*. 1987;28(4):345-376.
57. Aagaard P, Simonsen EB, Andersen JL, Magnusson P, Dyhre-Poulsen P. Neural adaptation to resistance training: changes in evoked V-wave and H-reflex responses. *J Appl Physiol*. 2002;92(6):2309-2318.
58. Enoka RM, Hutton RS, Eldred E. Changes in excitability of tendon tap and Hoffmann reflexes following voluntary contractions. *Electroencephalogr Clin Neurophysiol*. 1980;48(6):664-672.
59. Harris DA, Henneman E. Feedback signals from muscle and their efferent control. In: Mountcastle VB, ed. *Medical Physiology*. St Louis, MO: Mosby Co; 1980.
60. Andersson GB. Epidemiological features of chronic low-back pain. *Lancet*. 1999;354(9178):581-585.
61. Carey TS, Garrett JM, Jackman AM. Beyond the good prognosis: examination of an inception cohort of patients with chronic low back pain. *Spine (Phila Pa 1976)*. 2000;25(1):115-120.
62. Klenerman L, Slade PD, Stanley IM, et al. The prediction of chronicity in patients with an acute attack of low back pain in a general practice setting. *Spine (Phila Pa 1976)*. 1995;20(4):478-484.
63. Von Korff M. Studying the natural history of back pain. *Spine (Phila Pa 1976)*. 1994;19(18 suppl):2041S-2046S.
64. Nahin RL, Barnes PM, Stussman BJ, Bloom B. *Costs of Complementary and Alternative Medicine (CAM) and Frequency of Visits to CAM Practitioners: United States, 2007*. Hyattsville, MD: National Center for Health Statistics; 2009. National Health Statistics Report, number 18.
65. Gatterman MI, Cooperstein R, Lantz C, Perle SM, Schneider MJ. Rating specific chiropractic technique procedures for common low back conditions. *J Manipulative Physiol Ther*. 2001;24(7):449-456.
66. Haas M, Group E, Kraemer DF. Dose-response for chiropractic care of chronic low back pain. *Spine J*. 2004;4(5):574-583.
67. Hoiriis KT, Pflieger B, McDuffie FC, et al. A randomized clinical trial comparing chiropractic adjustments to muscle relaxants for subacute low back pain. *J Manipulative Physiol Ther*. 2004;27(6):388-398.
68. Hondras MA, Long CR, Cao Y, Rowell RM, Meeker WC. A randomized controlled trial comparing 2 types of spinal manipulation and minimal conservative medical care for adults 55 years and older with subacute or chronic low back pain. *J Manipulative Physiol Ther*. 2009;32(5):330-343.
69. Hurwitz EL, Morgenstern H, Harber P, et al. A randomized trial of medical care with and without physical therapy and chiropractic care with and without physical modalities for patients with low back pain: 6-month follow-up outcomes from the UCLA low back pain study. *Spine (Phila Pa 1976)*. 2002;27(20):2193-2204.
70. Licciardone JC, Brimhall AK, King LN. Osteopathic manipulative treatment for low back pain: a systematic review and meta-analysis of randomized controlled trials. *BMC Musculoskelet Disord*. 2005;6:43.
71. Licciardone JC, Stoll ST, Fulda KG, et al. Osteopathic manipulative treatment for chronic low back pain: a randomized controlled trial. *Spine (Phila Pa 1976)*. 2003;28(13):1355-1362.
72. MacDonald RS, Bell CM. An open controlled assessment of osteopathic manipulation in nonspecific low-back pain. *Spine (Phila Pa 1976)*. 1990;15(5):364-370.
73. Cohen MJ, Swanson GA, Naliboff BD, Schandler SL, McArthur DL. Comparison of electromyographic response patterns during posture and stress tasks in chronic low back pain patterns and control. *J Psychosom Res*. 1986;30(2):135-141.
74. Lehman GJ. Clinical considerations in the use of surface electromyography: three experimental studies. *J Manipulative Physiol Ther*. 2002;25(5):293-299.
75. Miller DJ. Comparison of electromyographic activity in the lumbar paraspinal muscles of subjects with and without chronic low back pain. *Phys Ther*. 1985;65(9):1347-1354.
76. Nouwen A, Van Akkerveken PF, Versloot JM. Patterns of muscular activity during movement in patients with chronic low-back pain. *Spine (Phila Pa 1976)*. 1987;12(8):777-782.
77. Sherman RA. Relationships between strength of low back muscle contraction and reported intensity of chronic low back pain. *Am J Phys Med*. 1985;64(4):190-200.
78. Finneran MT, Mazanec D, Marsolais ME, Marsolais EB, Pease WS. Large-array surface electromyography in low back pain: a pilot study. *Spine*. 2003;28(13):1447-1454.
79. Farina D, Merletti R, Enoka RM. The extraction of neural strategies from the surface EMG. *J Appl Physiol*. 2004;96(4):1486-1495.

80. Thelen DG, Ashton-Miller JA, Schultz AB. Lumbar muscle activities in rapid three-dimensional pulling tasks. *Spine*. 1996;21(5):605-613.
81. Damon BM, Louie EA, Sanchez OA. Physiological basis of muscle functional MRI. *J Gravit Physiol*. 2007;14(1):P85-P88.
82. Meyer RA, Prior BM. Functional magnetic resonance imaging of muscle. *Exerc Sport Sci Rev*. 2000;28(2):89-92.
83. Patten C, Meyer RA, Fleckenstein JL. T2 mapping of muscle. *Semin Musculoskelet Radiol*. 2003;7(4):297-305.
84. Yue G, Alexander AL, Laidlaw DH, Gmitro AF, Unger EC, Enoka RM. Sensitivity of muscle proton spin-spin relaxation time as an index of muscle activation. *J Appl Physiol*. 1994;77(1):84-92.
85. Adams GR, Duvoisin MR, Dudley GA. Magnetic resonance imaging and electromyography as indexes of muscle function. *J Appl Physiol*. 1992;73(4):1578-1583.
86. Goss DA Jr, Thomas JS, Clark BC. Novel methods for quantifying neurophysiologic properties of the human lumbar paraspinal muscles. *J Neurosci Methods*. 2011;194(2):329-335.
87. Skotte J, Hjortskov N, Essendrop M, Schibye B, Fallentin N. Short latency stretch reflex in human lumbar paraspinal muscles. *J Neurosci Methods*. 2005;145(1-2):145-150.
88. Strutton PH, Theodorou S, Catley M, McGregor AH, Davey NJ. Corticospinal excitability in patients with chronic low back pain. *J Spinal Disord Tech*. 2005;18(5):420-424.
89. Cleland JA, Flynn TW, Childs JD, Eberhart S. The audible pop from thoracic spine thrust manipulation and its relation to short-term outcomes in patients with neck pain. *J Man Manip Ther*. 2007;15(3):143-154.
90. Flynn TW, Fritz JM, Wainner RS, Whitman JM. The audible pop is not necessary for successful spinal high-velocity thrust manipulation in individuals with low back pain. *Arch Phys Med Rehabil*. 2003;84(7):1057-1060.
91. Brodeur R. The audible release associated with joint manipulation. *J Manipulative Physiol Ther*. 1995;18(3):155-164.
92. Cramer GD, Ross K, Pocius J, et al. Evaluating the relationship among cavitation, zygapophyseal joint gapping, and spinal manipulation: an exploratory case series. *J Manipulative Physiol Ther*. 2011;34(1):2-14.
93. Cleland JA, Childs JD, Fritz JM, Whitman JM, Eberhart SL. Development of a clinical prediction rule for guiding treatment of a subgroup of patients with neck pain: use of thoracic spine manipulation, exercise, and patient education. *Phys Ther*. 2007;87(1):9-23.
94. Cleland JA, Mintken PE, Carpenter K, et al. Examination of a clinical prediction rule to identify patients with neck pain likely to benefit from thoracic spine thrust manipulation and a general cervical range of motion exercise: multi-center randomized clinical trial. *Phys Ther*. 2010;90(9):1239-1250.
95. Cleland JA, Fritz JM, Kulig K, et al. Comparison of the effectiveness of three manual physical therapy techniques in a subgroup of patients with low back pain who satisfy a clinical prediction rule: a randomized clinical trial. *Spine*. 2009;34(25):2720-2729.
96. Hallegraeff JM, de Greef M, Winters JC, Lucas C. Manipulative therapy and clinical prediction criteria in treatment of acute nonspecific low back pain. *Percept Mot Skills*. 2009;108(1):196-208.
97. Fritz JM, Childs JD, Flynn TW. Pragmatic application of a clinical prediction rule in primary care to identify patients with low back pain with a good prognosis following a brief spinal manipulation intervention. *BMC Fam Pract*. 2005;6(1):29.
98. Childs JD, Fritz JM, Flynn TW, et al. A clinical prediction rule to identify patients with low back pain most likely to benefit from spinal manipulation: a validation study. *Ann Intern Med*. 2004;141(12):920-928.
99. Flynn T, Fritz J, Whitman J, et al. A clinical prediction rule for classifying patients with low back pain who demonstrate short-term improvement with spinal manipulation. *Spine*. 2002;27(24):2835-2843.

### Download JAOA PowerPoint Slides

Figures published in *JAOA—The Journal of the American Osteopathic Association* are now available as Microsoft PowerPoint slides on the JAOA's Web site. To take advantage of this new resource, JAOA readers should simply click on the link "Download as PowerPoint slide" when viewing the figure in the full text article on JAOA.org. Readers can also download all figures in an article by selecting the option "PPT Slides of All Figures" in the middle column of the Web page.